



Model#: FG4500iS

---

---

# Inverter Gasoline Generator OPERATOR'S MANUAL ORIGINAL INSTRUCTIONS

---

---

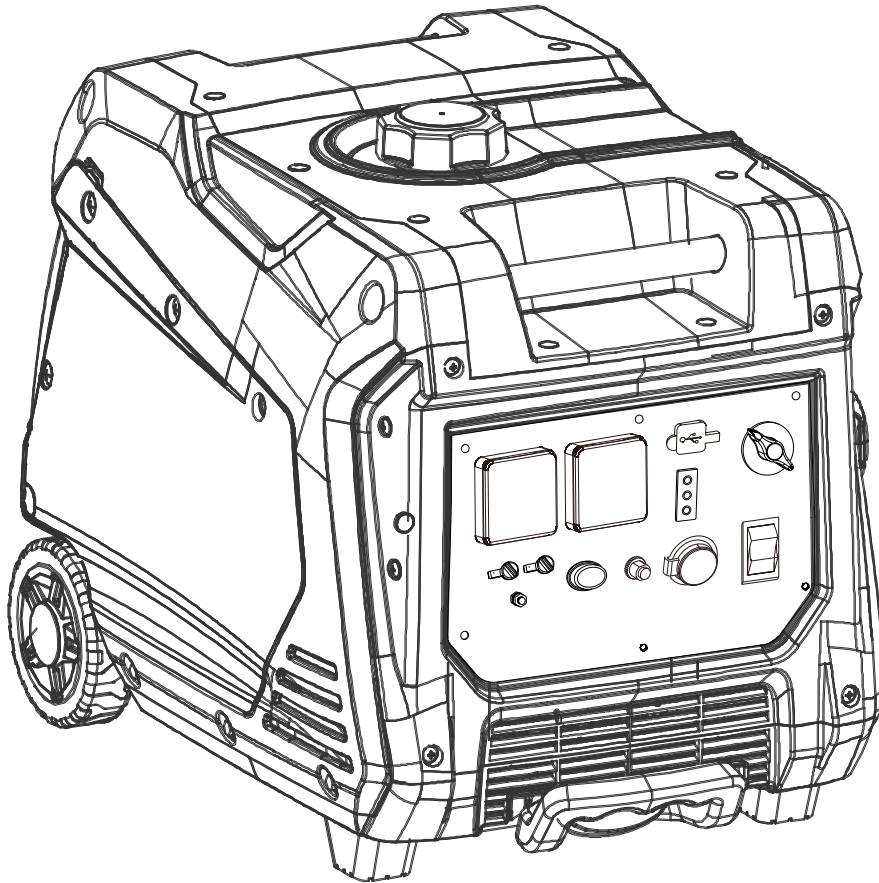

---

---

LICENCED BY: PULSAR PRODUCTS INC  
2051 S Lynx Place, Ontario, California, U.S.A 91761

# TABLE OF CONTENTS

<b>Introduction</b> .....	<b>3</b>
<b>Safety Rules</b> .....	<b>4</b>
Safety Symbols .....	4
Safety Instructions .....	4
<b>Features</b> .....	<b>7</b>
<b>Control Panel Functions</b> .....	<b>8</b>
ON/OFF Start Switch .....	8
USB Outlet .....	8
Indicator Lights .....	8
DC Protector .....	9
Engine “Economy” Control .....	9
Parallel Outlets .....	10
Fuel Cap Air Vent .....	10
Ground Terminal .....	10
<b>Assembly</b> .....	<b>11</b>
Connecting Generator to an Electrical System .....	11
Adding Fuel .....	11
Adding / Checking Oil .....	12
<b>Operation</b> .....	<b>13</b>
Grounding the Generator .....	13
How to Start Engine .....	13
How to Stop Engine .....	14
Attaching Electronic Devices .....	14
AC Parallel Operation .....	16
Don’t Overload Generator .....	17
Wattage Reference Guide .....	17
<b>Maintenance</b> .....	<b>18</b>
Maintenance Schedule .....	18
Checking Spark Plug .....	19
Changing Oil .....	20
Air Filter .....	21
Checking Muffler and Spark Arrestor .....	21
How to Clean Fuel Filter .....	22
<b>Transport &amp; Storage</b> .....	<b>22</b>
<b>Troubleshooting</b> .....	<b>24</b>
<b>Specifications</b> .....	<b>25</b>
<b>Wiring Diagram</b> .....	<b>26</b>

# INTRODUCTION

*Thank you for purchasing this superior quality portable generator from Ford Power Equipment. When operating and maintaining this product as instructed in this manual, your generator will give you many years of reliable service.*

## Product Specifications:

This generator is an engine-driven, inverter generator. It is designed to supply electrical power to operate tools, appliances, camping equipment, lighting, or serve as a back up power source during power outages.

AC Output	Voltage	230V
	Frequency	50Hz
	Power (COP)	3500W
	Power (PEAK)	3800W
DC Output	USB Outlet	5V DC 1.0/2.1A
	Cigarette Outlet	12V DC 8A
Engine	Displacement	224cc
	Engine Type	Single cylinder, 4 Stroke, OHV, Air Cooled
	Engine Oil Type	SAE 10W30
	Engine Oil Capacity	600ml / 20.2oz
	Fuel Tank Capacity	12L / 3.4Gal

- The rated power output of the generator, the following standard reference conditions shall be used
  - Total barometric pressure: 100kPa.
  - Air ambient temperature: 298K (25°C) .
  - Relative humidity: 30% .
  - Max. Altitude: 1000m.

# SAFETY RULES

## Safety Symbols



Indicates a potentially hazardous situation which could result in serious injury or death if not avoided.



Indicates a potentially hazardous situation which could result in damage to equipment or property.



Injury of damage



Read manual before use



Wear noise protection



Toxic fumes



Risk of fire



Risk of explosion



Risk of electric shock



Hot surface



Lifting hazard

## Safety Instructions

The manufacturer cannot anticipate every possible hazardous circumstance that the user may encounter. Therefore, the warnings in this manual, on tags, and on affixed decals are not all-inclusive. To avoid accidents, the user must understand and follow all manual instructions and use common sense.



Read and understand this manual in its entirety before operating this generator. Improper use of this generator could result in serious injury or death.



Exhaust gas is poisonous; do not operate in an unventilated area.

- Using a generator indoors **CAN KILL YOU IN MINUTES!**
- Carbon monoxide gas is a poisonous, odorless gas that can cause headache, confusion, fatigue, nausea, fainting, sickness, seizures, or death. If you start to experience any of these symptoms, **IMMEDIATELY** get fresh air and seek medical attention.
- Never use indoors, in a covered area, or in a confined space, even if doors and windows are open.
- Install a battery operated carbon monoxide alarm near bedrooms.
- Keep exhaust from this unit from entering a confined area through windows, doors, vents, or other openings.
- When working in areas where vapors could be inhaled, use a respirator mask according to all of its instructions.



# SAFETY RULES



**WARNING** Engine exhaust contains chemicals that lead to cause cancer and birth defects.

- Always wash hands after handling generator.



**WARNING** To reduce the risk of serious injury, avoid attempting to lift the generator alone.



**WARNING** Never exceed generator's wattage / amperage capacity. This could damage the generator and / or connected electrical devices.

- Check operating voltage and frequency requirements of all electrical devices prior to plugging them into the generator.



**WARNING** Never start or stop engine with electrical devices plugged in to the receptacles. Failure to do so could damage the generator and / or connected electrical devices.

- Always start the engine and let it stabilize before connecting any electronic devices.
- Disconnect all electronic devices before stopping the engine.



**WARNING** Starter and other moving parts can catch on clothing, jewelry, and hair.

- Do not wear loose clothing or gloves.
- Remove jewelry or anything else that could be caught in moving parts.
- Tie back or wear protective head covering to contain long hair.



**WARNING** Pull cord recoils rapidly and pulls arm towards engine faster than you can let go which could result in injury.

- To avoid the dangers of injury caused by the sudden change of rotation direction of the engine, pull starter cord slowly until resistance is felt, then pull rapidly.



**WARNING** Avoid contacting hot areas of this unit.

- Use caution around the muffler, cylinder, and other engine parts as they can be extremely hot.
- Allow hot components to cool before touching.



**WARNING** The precautions to be respected by the user in the case of re-supply by generating sets of an installation, depending on existing protective measures in this installation and applicable regulations.



**WARNING** Fuel is combustible and easily ignited. Do not refuel during operation. Do not refuel while smoking or near naked flames. Do not spill fuel.

# SAFETY RULES

## **WARNING**



**This generator produces a very high voltage which could result in burns or electrocution causing serious injury or death.**

- Never handle the generator, electronic devices, or any cord while standing in water, while barefoot, or when hands or feet are wet.
- Always keep the generator dry. Never operate generator in rain or under wet conditions.
- Never plug electronic devices into generator having frayed, worn, or bare wires. Never touch bare wires or make contact with receptacles.
- Never permit a child or unqualified person to operate generator. Keep children a minimum of 10 feet away from the generator at all times.
- If using the generator for back up power, notify the utility company.
- If connecting generator to a building's electrical system for standby power, you must use a qualified electrician to install a transfer switch. Failure to isolate the generator from the power utility could result in serious injury or death to electric utility workers.
  
- When using extension lines or mobile distribution networks the total length of lines for a cross section of 1.5 mm<sup>2</sup> should not exceed 60 m; for a cross section of 2.5 mm<sup>2</sup> this should not exceed 100 m.
- The generating set must not be connected to other power sources except with accessory advised by the manufacturer or other generators with the same model.
- Save these instructions. Refer to them frequently and use them to instruct others who may use this product. If you loan someone this product, loan these instructions also.

## **WARNING**



**Generator must be properly grounded to prevent electrocution.**

- Only operate generator on a level surface.
- Always connect the nut and ground terminal on the frame to an appropriate ground source.

## **WARNING**

**Only use this unit as intended or serious injury or death could result.**

- Do not bypass any safety device. Moving parts are covered with guards. Make sure all protective covers are in place.
- Never transport or make adjustments to this unit while it is running.
- Never insert objects through cooling slots.

## **WARNING**

**Never operate this unit if there are any broken or missing parts and only use Ford Power Equipment replacement parts specifically designed for this unit.**

- Improper treatment of generator can damage the unit and shorten it's life.
- Always repair this unit as specified in this manual. If you have any questions contact your dealer or consult a qualified service center.
- Shut generator off if electrical output is missing, unit vibrates excessively or begins to smoke, spark or emit flames.

## **WARNING**

**The user that he shall conform to regulations of electrical safety applicable to the place where the generating sets are used.**

# FEATURES

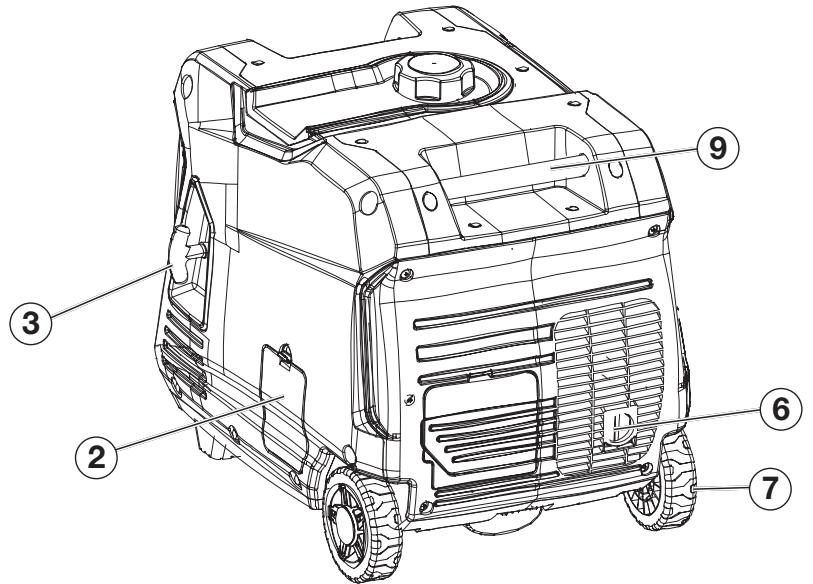
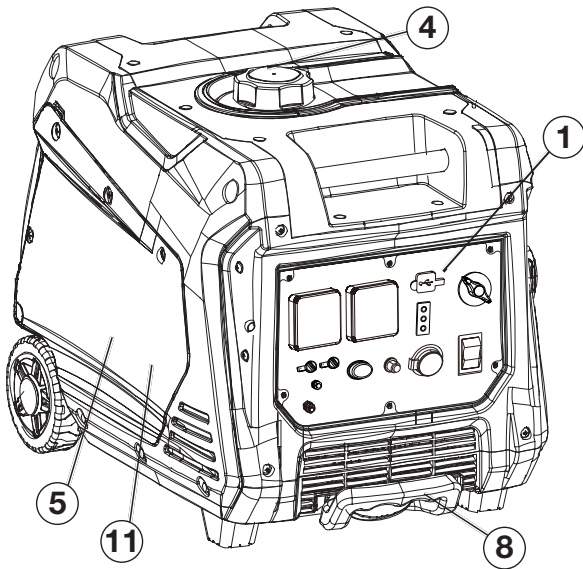

- ① Control Panel
- ② Oil Access Cover
- ③ Recoil Handle
- ④ Fuel Tank Cap
- ⑤ Engine Service Panel
- ⑥ Muffler and Spark arrestor
- ⑦ Never Flat Wheels
- ⑧ Telescoping Handle
- ⑨ Carry Handles

## CONTROL PANEL

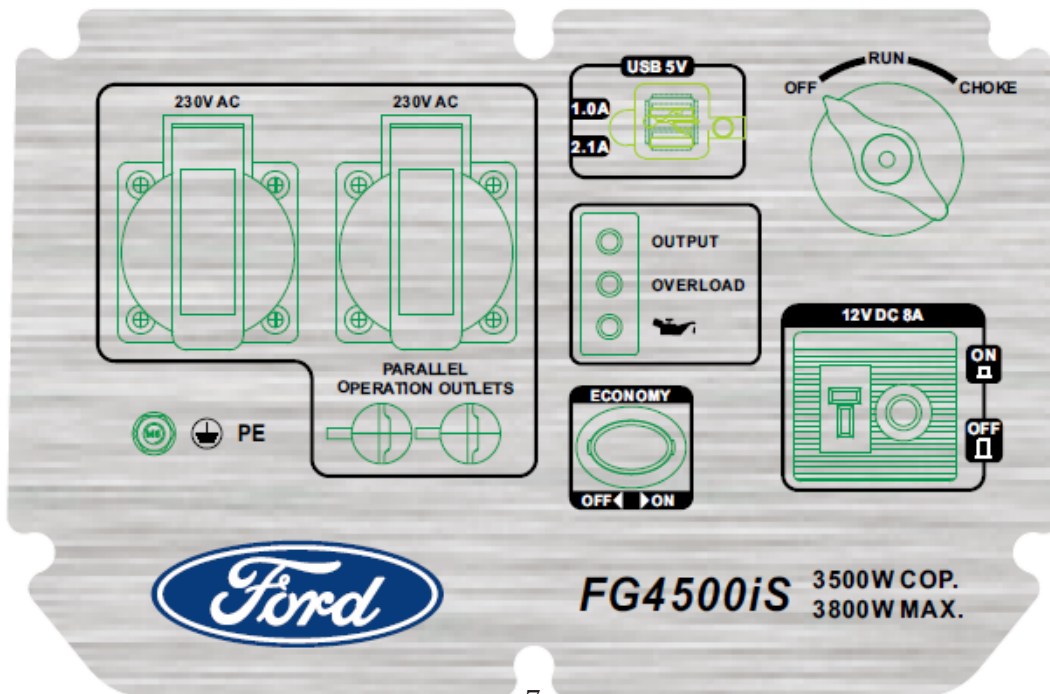

# CONTROL PANEL FUNCTIONS

## FUEL VALVE

“OFF” position, the fuel valve is switched off and the engine will not run.

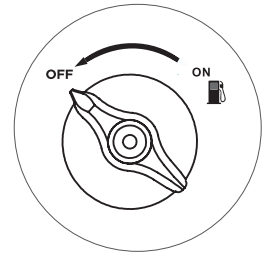

When the Start Switch is in the “ON” position the fuel valve is switched on and the engine can run.

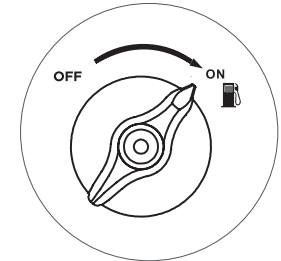

## USB Outlet

The Generator offers convenient (5V DC 1.0/2.1A) USB outlet to allow charging of USB devices like Tablets, MP3 players, GPS, Digital Cameras and other USB chargeable devices.

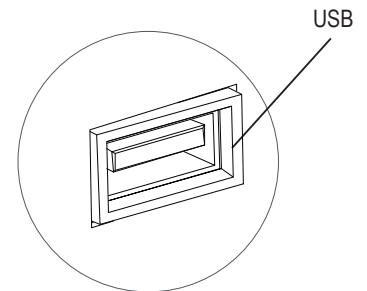

## Oil Warning Indicator Light

When the oil falls below the minimum level, the oil warning indicator light comes on and the engine stops automatically. The engine will not start until the proper amount of oil is in the crank case.

**Note:** If the oil warning indicator light does not come on and the engine stalls, turn the fuel valve to “ON” and pull the recoil starter.

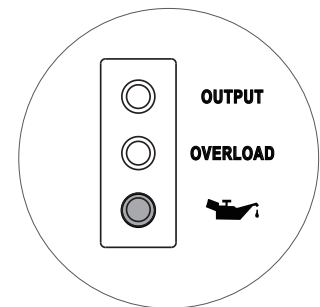

## Engine Overload Indicator Light

If the engine overload indicator light comes on, the generator's wattage / amperage capacity has been exceeded by connected electrical devices or by a power surge. When this occurs, the green AC Pilot Indicator Light will go off. The engine will continue to run, (but the red Engine Overload Indicator Light will stay on and power will no longer be supplied to connected electronic devices.)

**Note:** The engine overload indicator light may turn on for a few seconds when attaching a load due to a power surge. This is normal.

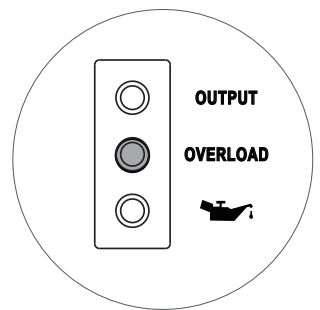

# CONTROL PANEL FUNCTIONS

## How to Correct

1. Disconnect any electronic devices then stop the engine.
2. Reduce the total wattage of connected electronic devices until it is within the generator's rated output.
3. Inspect the Air Inlet and Control Panel for any blockage. Remove blockage if found.
4. Restart Engine.

## AC Pilot Indicator Light

The green AC Pilot Indicator Light comes on when the engine starts and generates power.

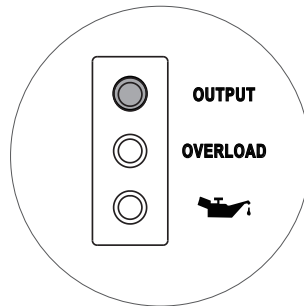

## DC Circuit Breaker

When the DC Circuit Breaker is in the "ON" position, the generator is able to supply power to connected electronic devices. When the DC Circuit Breaker is in the "OFF" position, the generator will no longer supply power. The DC Circuit Breaker automatically turns "OFF" when connecting electronic devices to the generator that exceed the generator's rated output. If the DC Circuit Breaker turns off, reduce the load of connected electronic devices until the load is within the specified rated output. To re-establish power, return the DC Circuit Breaker back to the "ON" position.



### CAUTION!

If the DC Circuit Breaker turns off again, stop using the generator immediately and consult a qualified electrician or small Engine repair shop.

## Engine Economy Control

- When the Engine Economy switch is turned to the "ON" position, the economy control unit automatically determines the generator's proper engine speed based on the connected electronic load. This results in superior fuel economy and reduces noise.
- When the Economy switch is turned to the "OFF" position, the engine runs at the rated speed of 3,100 rpm.

# CONTROL PANEL FUNCTIONS

Note: The Economy switch must be turned to the “OFF” position when using electronic devices that require a large starting current, such as a compressor.

## Parallel Outlets

Located just above the Ground Terminal, the generator's Parallel Outlets enable a user to run two FG4500iS generator's simultaneously. This operation requires special cables. When operating parallel generators, the rated output is 7.0kVA and the rated current is 16A/220VAC. For cables and instructions consult a FORD dealer for a PARALLEL OPERATION CABLE KIT.



### WARNING!

**Never connect generators that are different models.**

- Only connect this generator to another FG Series Standard Generator.
- Only use a parallel operation cable kit designed to work with this Generator.

## Fuel Tank Cap

Turn counterclockwise to remove the fuel tank cap.

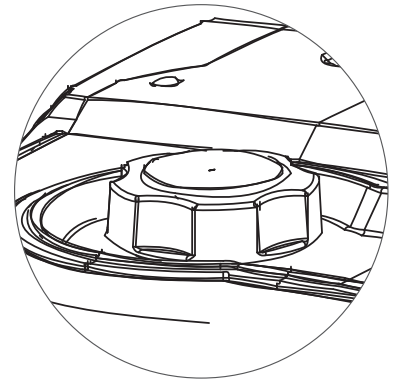

## Ground Terminal

The generator's ground terminal must always be used to connect the generator to a driven ground rod. Connect the ground terminal to the driven ground rod with a 12 AWG (American Wire Gage) copper wire. The wire connects to the terminal between the lock washer and nut. Tighten the nut securely to ensure good connection. Grounding the generator protects you from electric shock that results from a build up of static electricity or undetected ground faults.

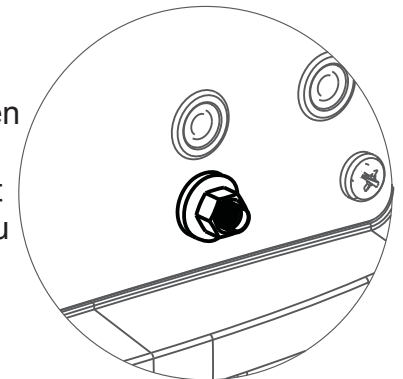

### WARNING!



**Generator must be properly grounded to prevent electrocution.**

- Only operate generator on a level surface.
- Always connect the nut and ground terminal on the frame to an appropriate ground source.

# ASSEMBLY

## Connecting Generator to an Electrical System

- If connecting generator to a building's electrical system for standby power, you must use a qualified electrician to install a transfer switch. The power from the generator must be isolated from the circuit breaker or alternative power source. The connection must comply with all electrical codes and applicable laws.

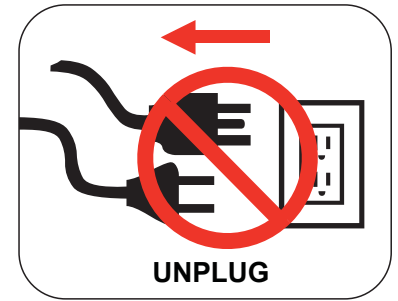

Never directly connect generator to a household power source.



### WARNING!



**This generator produces a very high voltage which could result in burn or electrocution causing serious injury or death.**

- Never handle the generator, electronic devices, or any cord while standing in water, while barefoot, or when hands or feet are wet.
- Always keep the generator dry. Never operate generator in rain or under wet conditions.
- Use a ground fault circuit interrupter (GFCI) in a damp or highly conductive area, such as metal decking or steel work.
- Never plug electronic devices into generator having frayed, worn, or bare wires. Never touch bare wires or make contact with receptacles.
- Never permit a child or unqualified person to operate generator. Keep children a minimum of 10 feet away from the generator at all times.
- If using the generator for back up power, notify the utility company.
- If connecting generator to a building's electrical system for standby power, you must use a qualified electrician to install a transfer switch. Failure to isolate the generator from the power utility could result in serious injury or death to electric utility workers.

## Adding Fuel

- Set generator on a clean and level surface in an area that is well ventilated.
- Remove fuel cap.
- Insert a funnel into the fuel tank and carefully pour gasoline into the tank until fuel level reaches about 1 ½ inches below the top of the neck. Be careful not to overfill the tank to provide space for fuel expansion.
- Replace fuel cap and secure tightly.

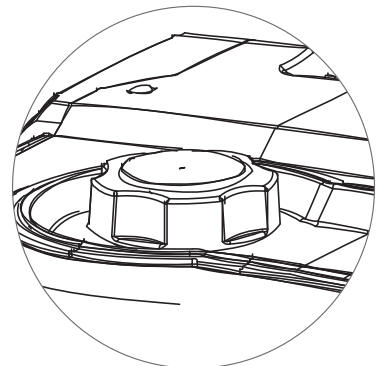

Turn cap counterclockwise to remove.

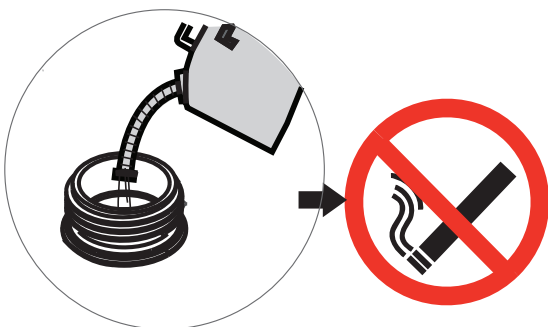

Do not smoke when adding fuel.

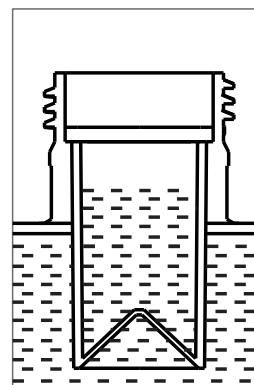

Do not overfill the fuel tank.  
Provide space for fuel expansion.



# ASSEMBLY

## Adding /Check ing Engine Oil

- Place generator on a level surface.
- Unclip and remove the oil service panel to access the oil fill/drain plug.

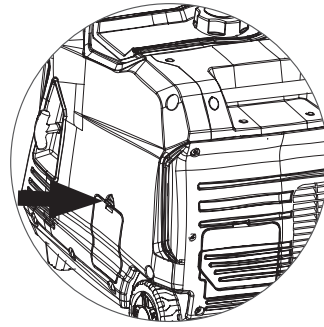

- Remove the crankcase dipstick.

**Recommended Oil:** SAE 10W-30

**Oil Capacity:** 0.6L (20.2oz)

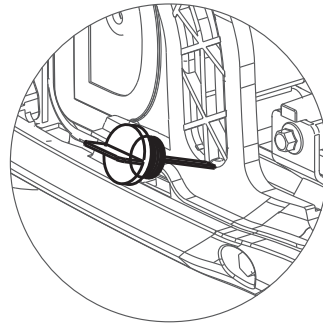

- Insert a funnel into the crankcase dipstick hole and carefully add the specified amount of 4-Cycle engine oil (SAE 10W-30) to empty reservoir until or oil reaches the outer edge of the oil fill hole (crankcase dipstick hole).
- Be sure to replace dipstick and securely tighten before attempting to start the engine.
- To check oil, set generator on a level surface, wipe dipstick clean, then reinsert dipstick without re-threading.



### CAUTION!

Generator has been shipped without engine oil. You must add oil before first operating this generator. Always check oil level before each operation.



# OPERATION

## Grounding the Generator

To avoid electrocution, this generator must be properly grounded prior to use. For instructions see Control Panel Functions pg. 10.

## Standard Atmospheric Conditions

Ambient Temperature: 77°F (25°C)

Barometric Pressure: 100kPa

Relative Humidity: 30%

Generator output will vary due to changes in temperature, altitude, and humidity. If the temperature, humidity, or altitude are higher than standard atmospheric conditions, the generator's output will be reduced. The load attached to the generator must therefore be reduced.

## How to Start Engine

- Place generator on a level surface. All electrical loads **MUST** be disconnected from generator.
- Turn the Economy switch to "OFF" position.
- Turn the Fuel valve to "on" position.

### For recoil start

- a. Turn the Engine switch to "on" position.
- b. Pull recoil handle (starter cord) slowly until resistance is felt, then pull rapidly.

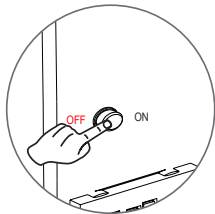

Economy switch

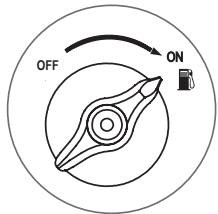

Fuel valve switch

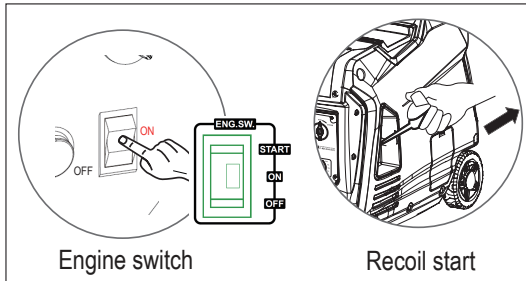

Engine switch

Recoil start



## WARNING!

**Pull cord recoils rapidly and pulls arm towards engine faster than you can let go which could result in injury.**

- To avoid recoil, pull starter cord slowly until resistance is felt, then pull rapidly.

**Note:** To start the generator with the Economy switch in the "ON" position

- Disconnect all electrical loads from generator.
- If ambient temperature is below 32°F (0°C) allow about 3 minutes for the engine to warm up.
- The Economy is in "ON" position, the unit returns to normal operation after the above warm up time.
- Economy switch must be turned to the "OFF" position when using electronic devices that require a large starting current, such as a compressor.

# OPERATION

## How to Stop Engine

- Turn the Economy switch to the "OFF" position.
- Disconnect any electronic device. All loads **MUST** be disconnect from the generator. Never start or stop the engine with electrical devices plugged in to the receptacles.
- Push engine switch to "OFF" position.
- Turn the fuel valve to "OFF" position.

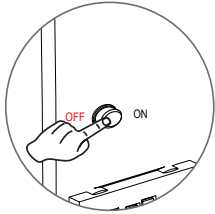

Economy switch

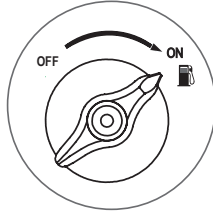

Fuel valve switch



### WARNING!

**Never start or stop engine with electrical devices plugged in to the receptacles. Failure to do so could damage the generator and / or connected electrical devices.**

- Always start the engine and let it stabilize before connecting any electronic devices.
- Disconnect all electronic devices before stopping the engine.

# OPERATION

## How to Attach Electronic Devices

1. Before Starting generator
  - Make sure the generator is grounded (see page 10 for instructions).
  - Make sure the attached load is within the generator rated output and the receptacle's rated current.
  - Make sure all electrical cords and receptacles are in good condition.
  - Make sure all electronic devices are turned "OFF" before plugging them into the generator.
2. Start engine
3. If the attached load is small, turn the Economy switch to the "ON" position. For a larger load, or if attaching multiple electronic devices turn the Economy switch to the "OFF" position.
4. Make sure the green AC pilot indicator light is on.
5. When engine has stabilized, plug in and turn on first load. It is strongly recommended to plug in devices with the largest output first and the smallest output last to help prevent overloading the generator.
6. Allow generator output to stabilize (engine and attached devices run evenly) before plugging in the next load.

# OPERATION

## AC Parallel Operation

It is possible to connect two FG4500iS generators to each other, using a parallel cable kit, to increase available power output.

- Connect PARALLEL OPERATION CABLES to two FG4500iS generators according to the instructions provided with the cable kit.
- Make sure the Economy switch is in the same position on both generators.
- All electronic devices should be turned “OFF” and disconnected from generators prior to starting generator engines.
- Start generator engines. Make sure the green output indicator light comes on for each generator.
- When engines have stabilized, plug in electronic device to AC receptacle and turn on first load.
- Allow generator output to stabilize (engine and attached devices run evenly) before plugging in the next load.

Limit operation time to 3 seconds for load requiring maximum output. For continuous operation, do not exceed the rated output.

**Note:** It is strongly recommended to plug in devices with the largest output first and the smallest output last to help prevent overloading the generator.

**Note:** Most electronic devices require power beyond its rated wattage to start. This additional power is referred to as surge watts and usually lasts between 2-3 seconds. When an electronic device is started, the red overload indicator may come on. This is normal. If the light stays on disconnect all electronic devices and stop the engine. Refer to “Engine Overload Indicator Light” on page 8.



### WARNING!

**Only connect electronic devices to the generator that are in good working order and do not exceed the rated power supply of the parallel generators or the desired receptacle.**

- A faulty appliance or power cord can create an electric shock. Do not use electronic devices that have a damaged cord or plug.
- If an appliance begins to operate abnormally, becomes sluggish, or stalls, turn off and disconnect appliance immediately. The appliance may have a fault or its rated load capacity exceeds the power supply of the generator.
- To avoid damage to generator or electronic device, do not connect a load to the generator if its electrical rating exceeds that of the receptacle.



### WARNING!

**Never connect generators that are different models.**

- Only connect this generator to another FG4500iS generator.
- Only use a FORD approved parallel operation cable kit to connect generators.
- Do not run generators in parallel operation in excess of rated power.
- The parallel cable must be removed if operating only one generator.
- Never disconnect or remove the parallel operation cable while generator is still running.

# OPERATION

## Don't Overload Generator

Make sure you can supply enough rated watts for all electronic devices connected to the generator. Rated watts refer to the power a generator must supply to keep a device running. Surge watts refer to the power a generator must supply to start an electronic device. This power surge for starting a device usually lasts between 2-3 seconds but this additional output must be taken into account when selecting the electronic devices you plan to attach to the generator. To prevent overloading the generator take the following steps:

1. Add up the total rated wattage of all electronic devices that will be connected to the generator simultaneously.
2. Estimate surge watts by adding the item(s) with the highest output (it is unnecessary to calculate the surge output for all devices as they should be connected one at a time).
3. Add the Surge Watts to the total Rated Watts in step 1. Keep total load within generator's power capacity.

## Wattage Reference Guide

(Wattages listed are just approximations. Check electronic device for actual wattage)

Essentials	Rated Watts	Surge Watts
75W Light Bulbs	75 each	75 each
18 CU Ft Refrigerator / Freezer	800	2200
Furnace Fan (1/3 HP)	800	2350
Sump Pump (1/3 HP)	1000	2000
Water Pump (1/3 HP)	1000	3000
<b>Heating/Cooling</b>		
Dehumidifier	650	800
Table Fan	800	2000
Electric Blanket	400	400
Space Heater	1800	1800
<b>Kitchen</b>		
Blender	300	900
Toaster (2 slice)	1000	1600
Coffee Maker	1500	1500
Electric Range (1 element)	1500	1500
Dishwasher	1500	3000
<b>Laundry Room</b>		
Iron	1200	1200
Washing Machine	1150	3400
Gas Clothes Dryer	700	2500

Bathroom	Rated Watts	Surge Watts
Hair Dryer	1250	0
Curling Iron	1500	0
<b>Family Room</b>		
X-Box or Play Station	40	0
AM/FM Radio	100	100
VCR	100	100
Color TV (27")	500	500
<b>Home Office</b>		
Fax Machine	65	0
Personal Computer (17" Monitor)	800	0
Laser Printer	950	0
Copy Machine	1600	0
<b>Power Tools</b>		
1000W Quartz Halogen Work Light	1000	0
Airless Sprayer (1/3 HP)	600	1200
Reciprocity Saw	960	0
Circular Saw (7 1/4")	1400	2300
Mitar Saw (10")	1800	1800
Table/Radial Arm Saw	2000	2000
Electric Drill (1/2 HP, 5.4 Amps)	600	900

# MAINTENANCE

Regular maintenance will extend the life of this generator and improve its performance. The warranty does not cover items that result from operator negligence, misuse, or abuse. To receive full value from the warranty, operator must maintain the generator as instructed in this manual, including proper storage.



## WARNING!

Before inspecting or servicing this machine, make sure the engine is off and no parts are moving. Disconnect the spark plug wire and move it away from the spark plug.



## CAUTION!

If you are unsure of how to perform a maintenance task, have the unit serviced by a PULSAR dealer



## CAUTION!

Only use specified FORD replacement parts.

## Maintenance Schedule

### Pre-Operation Steps

Before starting the engine, perform the following pre-operation steps:

- Check the level of the engine oil and the fuel tank level. Check for any leakage.
- Check fuel hose for cracks or damage. Replace if necessary.
- Make sure the air filter is clean.
- Remove any debris that has collected on the generator and around the muffler and controls. Use a vacuum cleaner to pick up loose debris. If dirt is caked on, use a soft bristle brush.
- Inspect the work area for hazards.

### After Each Use

Follow the following procedure after each use:

- Shut off engine.
- Store unit in a clean and dry area.

<b>After First 5 Hours</b>	Change Oil.
<b>After 8 Hours or Daily</b>	Clean Debris.
	Check Engine Oil Level.
<b>6 Months (100 hr Use)</b>	Check and Clean Air Filter Element. (Service more often under wet or dusty conditions.)
	Change Engine Oil. (Service more often under dirty or dusty conditions.)
	Check Muffler Screen. Replace if necessary.
	Service Spark Plug.
	Inspect Muffler and Spark Arrester.
<b>12 Months (300 hr Use)</b>	Clean Fuel Filter. Replace if necessary.
	Check Crankcase Breather Hose for cracks or damage. Replace if necessary.
	De-carbonize cylinder head. See dealer.
	Check and adjust Valve Clearance. See dealer.
	Check all Fittings and Fasteners. See dealer.

# MAINTENANCE

## Checking Spark Plug

- Remove the Engine Service Panel to gain access to the Spark plug
- Remove cap. Then remove spark plug cap.
- Disconnect the spark plug wire from the spark plug.
- Before removing the spark plug, clean the area around its base to prevent debris from entering the engine.
- Insert a spark plug socket wrench through the opening on the outside of the cover. Turn the wrench counterclockwise.
- Check for discoloration and clean carbon deposits off the electrode with a wire brush.
- Check the electrode gap and slowly adjust to 0.7 - 0.8mm (0.028-0.031 in) if necessary.
- Reinstall spark plug and tighten to Torque 20.0Nm (14.8ft-lb).
- If spark plug is worn replace only with an equivalent replacement part. Spark plug should be replaced annually.
- Reconnect spark plug wire.
- Replace spark plug cap, then replace cap.

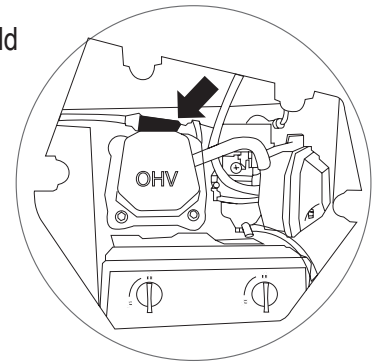
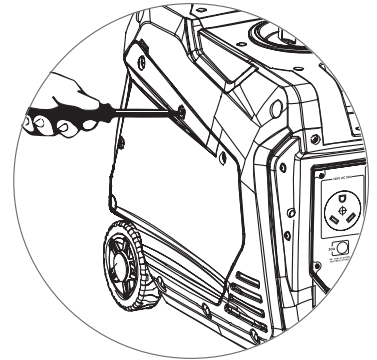

Pull off Spark Plug Cover

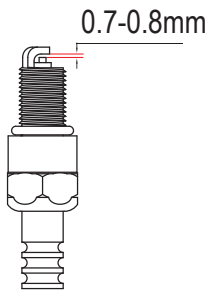

**Standard Spark Plug:** F7TC/F7RTC

**Spark Plug Gap:** 0.7 - 0.8mm (0.028-0.031 in)

**Spark Plug Torque:** 20.0Nm (14.8ft-lb)

## Carburetor Adjustment

The carburetor is low emission and is equipped with a non-adjustable idle mixture valve. If adjustment is needed contact an authorized dealer.

## Oil Recommendations

- Do not use special additives.
- Outdoor temperatures determine the proper oil viscosity for the engine. Use the chart to select the best viscosity for the outdoor temperature range expected.

Note: \* Below 40 °F (4 °C) the use of SAE 30 will result in hard starting.

\*\* Above 80 °F (27 °C) the use of 10W-30 may cause increased oil consumption.

Check oil level more frequently

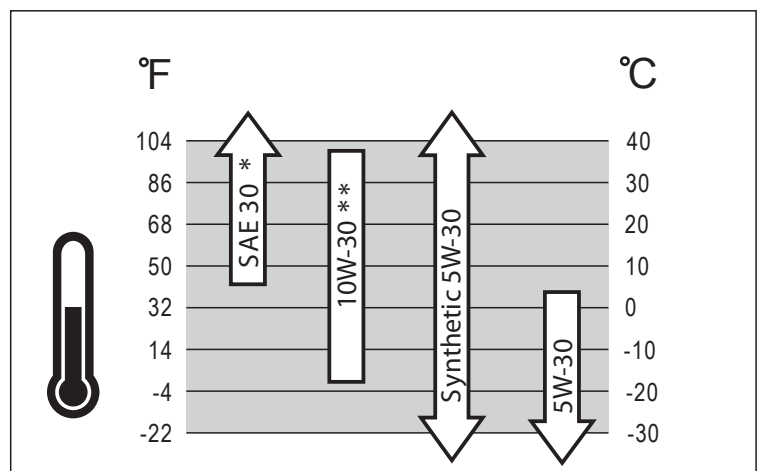

# MAINTENANCE

## Changing Oil

- Place generator on a level surface.
- Run the generator for several minutes until the engine is warm. Turn off generator.
- Remove screws, then remove outer casing side cover.
- Remove the crankcase dipstick.
- Place an oil pan underneath the engine. Tilt generator to collect used oil. Allow oil to drain completely.
- Return generator to a level surface.
- Carefully add 4-Cycle engine oil (SAE 10W-30) to empty reservoir until oil reaches the outer edge of the oil fill hole (Crankcase Dipstick hole).
- Use a clean rag to wipe up any spilled oil.
- Replace crankcase dipstick.
- Reinstall outer casing side cover and tighten screws.

**Recommended Engine Oil:** SAE 10W-30

**Recommended Engine Oil Grade:** API Service SE type or higher quality of engine oil.

**Engine Oil Quantity:** 0.6L (20.2 oz)



**CAUTION!**

Do not tilt generator when adding oil. This could result in overfilling which could damage the engine.



**CAUTION!**

Make sure no foreign matter enters the crankcase

## High Altitude Operation

At high altitude, the standard carburetor air/fuel mixture will be too rich. Performance will decrease, and fuel consumption will increase. A very rich mixture will also foul the spark plug and cause hard starting. Operation at an altitude that differs from that at which this engine was certified, for extended periods of time, may increase emissions. High altitude performance can be improved by specific modifications to the carburetor. If you always operate your generator at altitudes above 5,000 feet (1,500 meters), have your dealer perform this carburetor modification. This engine, when operated at high altitude with the carburetor modifications for high altitude use, will meet each emission standard throughout its useful life. Even with carburetor modification, engine horsepower will decrease about 3.5% for each 1,000-foot (300-meter) increase in altitude. The effect of altitude on horsepower will be greater than this if no carburetor modification is made.



# MAINTENANCE

## Air Filter

A dirty air filter will reduce the life span of the engine, make it difficult to start the engine, and reduce the unit's performance. Replace with new filter annually.

- To clean, remove the screws then remove outer casing.
- Remove the screws then remove air filter cover.
- Remove the foam element.
- Wash the foam element in solvent and let dry.
- Reinsert the foam element into the air filter case.

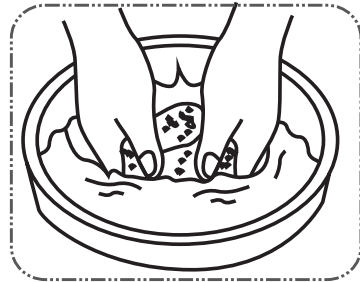
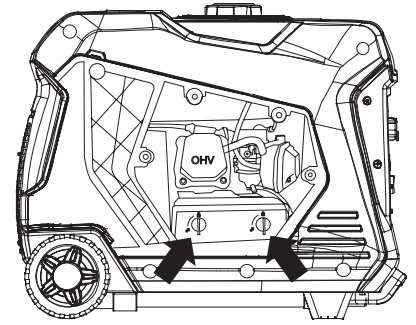

Unlock Air Filter Cover



### CAUTION!

Do not run the generator without reinstalling the foam element or excessive piston and cylinder wear may result.

## Checking Muffler and Spark Arrester

- Inspect muffler for cracks, corrosion, or other damage.
- Remove screws, then remove the muffler cover as shown.
- Loosen bolt, then remove muffler cap, muffler screen, and spark arrester.
- Check the muffler screen and spark arrester for carbon deposits. Remove carbon deposits with a wire brush.
- Check the muffler screen and spark arrester for damage. If damaged replace with FORD replacement parts specifically designed for this unit.
- Install the spark arrester. Align the spark arrester projection with the hole in the muffler pipe.
- Install the muffler screen and muffler cap.
- Install the outer casing and tighten the screws.

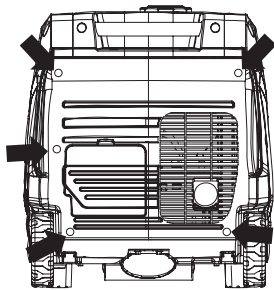

Remove Muffler Access Panel



### WARNING!



Avoid contacting hot areas of this unit.

- Use caution around the muffler, cylinder, and other engine parts as they can be extremely hot.
- Allow hot components to cool before touching.

# MAINTENANCE

## Fuel Tank Filter

- To clean, remove fuel cap and filter.
- Clean filter with gasoline.
- Wipe the filter with a clean rag.
- Install filter.
- Install fuel cap.

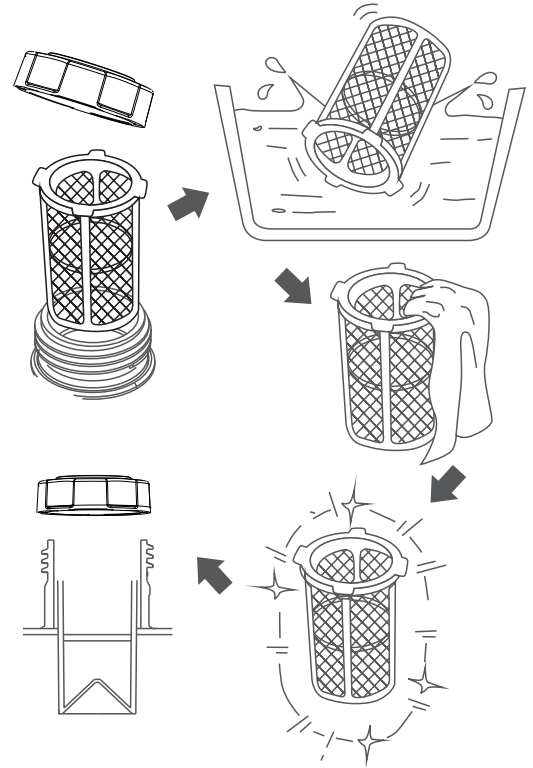

## Fuel Filter

- To clean, remove screws, remove outer casing, and drain fuel.
- Lift and hold onto the clamp, then remove hose from tank.
- Take out fuel filter.
- Clean filter with gasoline.
- Wipe the filter with a clean rag and return filter to tank.
- Install hose and clamp.
- Open fuel valve. Inspect for leakage.
- Install outer casing and tighten screws.

## Storage and Transportation of the Generator:

When transporting the generator, turn the 3 in 1 Start Switch (ON/OFF and Choke) OFF. Keep the generator level to prevent fuel spillage. Fuel vapor or spilled fuel may ignite.

- Remove any debris that has collected on the generator and around the muffler and control panel. Use a brush or vacuum to remove loose dirt.
- Inspect air cooling slots. Remove any debris if obstructed.
- For short-term storage, start the generator once every 7 days.
- For semi-long term storage, add fuel stabilizer to prevent stale fuel from causing acid and gum deposits in the fuel system and carburetor.
- For long-term storage, drain the fuel.
- Store indoors to prevent freezing and use a protective cover to protect from dust.
- The generator must be Shipped, Run, and Stored in the upright position as seen in this image.

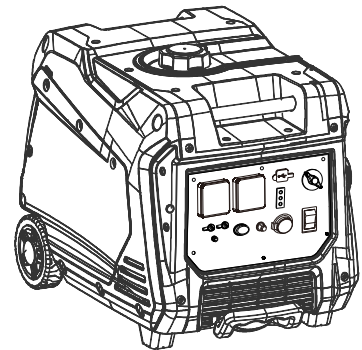

# MAINTENANCE



## WARNING!

Contact with a hot engine or exhaust system can cause serious burns or fires. Let the engine cool before transporting or storing the generator.



## CAUTION!

Take care not to drop or strike the generator when transporting. Do not place heavy objects on the generator.

### Engine Long Term Storage:

- Remove the spark plug and pour about 1 teaspoon of 10W30 Engine oil into the spark plug hole. Reinstall the spark plug. With the 3 in 1 switch in the “OFF” position pull the recoil starter cord several times to coat the cylinder walls with oil.
- Slowly pull the recoil starter until you feel the engine build compression (when you feel resistance). Leave the engine in this state as this will prevent any corrosion on the cylinder walls if stored for a long period of time.

### How to drain fuel

- Turn Fuel switch to the “OFF” position.
- Remove fuel cap and fuel tank filter.
- Use a siphon to transfer gasoline from generator into a gasoline approved container.
- Wipe up any spilled fuel with a clean rag.
- Start generator engine and let it run until it stops and all remaining fuel is consumed. Do not connect electronic devices to generator during this process.
- Remove outer casing screws, then remove outer casing.
- Drain fuel from carburetor by loosening the drain screw on the carburetor float chamber.
- Turn the Fuel switch to “OFF”
- Tighten the drain screw.
- Install the outer casing and tighten screws.

# TROUBLESHOOTING

<b>Problem</b>	<b>Cause</b>	<b>Solution</b>
Generator is running, but does not supply power.	<ol style="list-style-type: none"> <li>1. DC Circuit Breaker is "OFF"</li> <li>2. Green AC Pilot Light Indicator is off.</li> <li>3. Poor connection</li> <li>4. Defective cord set</li> <li>5. Connected device is faulty</li> <li>6. Fault in generator</li> </ol>	<ol style="list-style-type: none"> <li>1. Turn DC Circuit Breaker "ON"</li> <li>2. Stop engine and restart.</li> <li>3. Check and repair</li> <li>4. Check and repair</li> <li>5. Connect a device that is working properly</li> <li>6. Contact service department</li> </ol>
Engine runs good without load but bogs down when loads are connected	<ol style="list-style-type: none"> <li>1. Short circuit in connected device</li> <li>2. Generator is overloaded</li> <li>3. Clogged fuel filter</li> <li>4. Engine speed is too slow</li> <li>5. Short circuit in generator</li> </ol>	<ol style="list-style-type: none"> <li>1. Disconnect device</li> <li>2. See pg 8.pg9 "Don't overload generator"</li> <li>3. Clean or replace fuel filter</li> <li>4. Contact service department</li> <li>5. Contact service department</li> </ol>
Engine will not start, shuts down during operation, or starts and runs rough.	<ol style="list-style-type: none"> <li>1. 3 in 1 switch set to "OFF"</li> <li>2. Dirty Air filter</li> <li>3. Clogged fuel filter</li> <li>4. Out of fuel or Stale fuel</li> <li>5. Spark plug wire disconnected from spark plug</li> <li>6. Bad spark plug</li> <li>7. Water in fuel</li> <li>8. Overchocking</li> <li>9. Low oil level</li> <li>10. Engine has flooded</li> <li>11. Faulty ignition</li> </ol>	<ol style="list-style-type: none"> <li>1. Turn switch to "ON" then pull recoil starter.</li> <li>2. Clean or replace Air filter</li> <li>3. Clean or replace fuel filter</li> <li>4. Replace fuel</li> <li>5. Reconnect spark plug wire</li> <li>6. Clean or replace spark plug</li> <li>7. Drain fuel tank and replace fuel</li> <li>8. Turn off choke</li> <li>9. Add oil level.</li> <li>10. Wait 5 minutes and recrank engine</li> <li>11. Contact FORD dealer</li> </ol>
Engine lacks power	<ol style="list-style-type: none"> <li>1. Generator is overloaded</li> <li>2. Clogged fuel filter</li> <li>3. Dirty Air filter</li> <li>4. Engine needs servicing</li> </ol>	<ol style="list-style-type: none"> <li>1. See pg 8.pg9 "Don't overload generator"</li> <li>2. Clean or replace fuel filter</li> <li>3. Replace Air filter</li> <li>4. Contact service department</li> </ol>
Engine "hunts" or falters	<ol style="list-style-type: none"> <li>1. Choke was removed too soon</li> <li>2. Clogged fuel filter</li> <li>3. Carburetor is running too rich or too lean</li> </ol>	<ol style="list-style-type: none"> <li>1. Move to choke until engine runs evenly</li> <li>2. Clean or replace fuel filter</li> <li>3. Contact service department</li> </ol>

# SPECIFICATION

Model No.		FG4500iS	
Generator	Type		Inverter
	Rated Frequency		50Hz
	Rated Voltage		230V
	Peak Output Power		3.8kW
	Rated Output Power		3.5kW
	Power Factor		1.0
	THD%		≤3%
	DC Output		12V/8A
	Overload Protect	DC	Yes
AC		Yes	
Engine	Engine		
	Engine Type		Single Cylinder, 4-Stroke, Forced Air Cooling, OHV
	Displacement / cc		224
	Fuel Type		Unleaded Gasoline
	Fuel Tank Capacity		12L
	Engine Oil Capacity		600ml / 20.2oz
	Spark Plug Model No.		F7TC/F7RTC
	Starter Type		Recoil Start
Generator Set			
Net Weight		43.5kg	

Ford power continually seeks advancement in quality and product desing. Therefore, while this manual contains the most current product information available at the time of printing, there may be minor discrepancies between your product and this manual. If there is any question concerning this manual, please consult a FORD dealer. This manual should be considered a permanent part of this product and should remain with this product when resold. Products and specifications are subject to change without notice.

# WIRING DIAGRAM

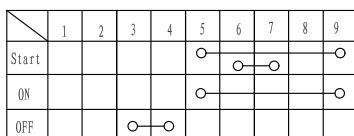
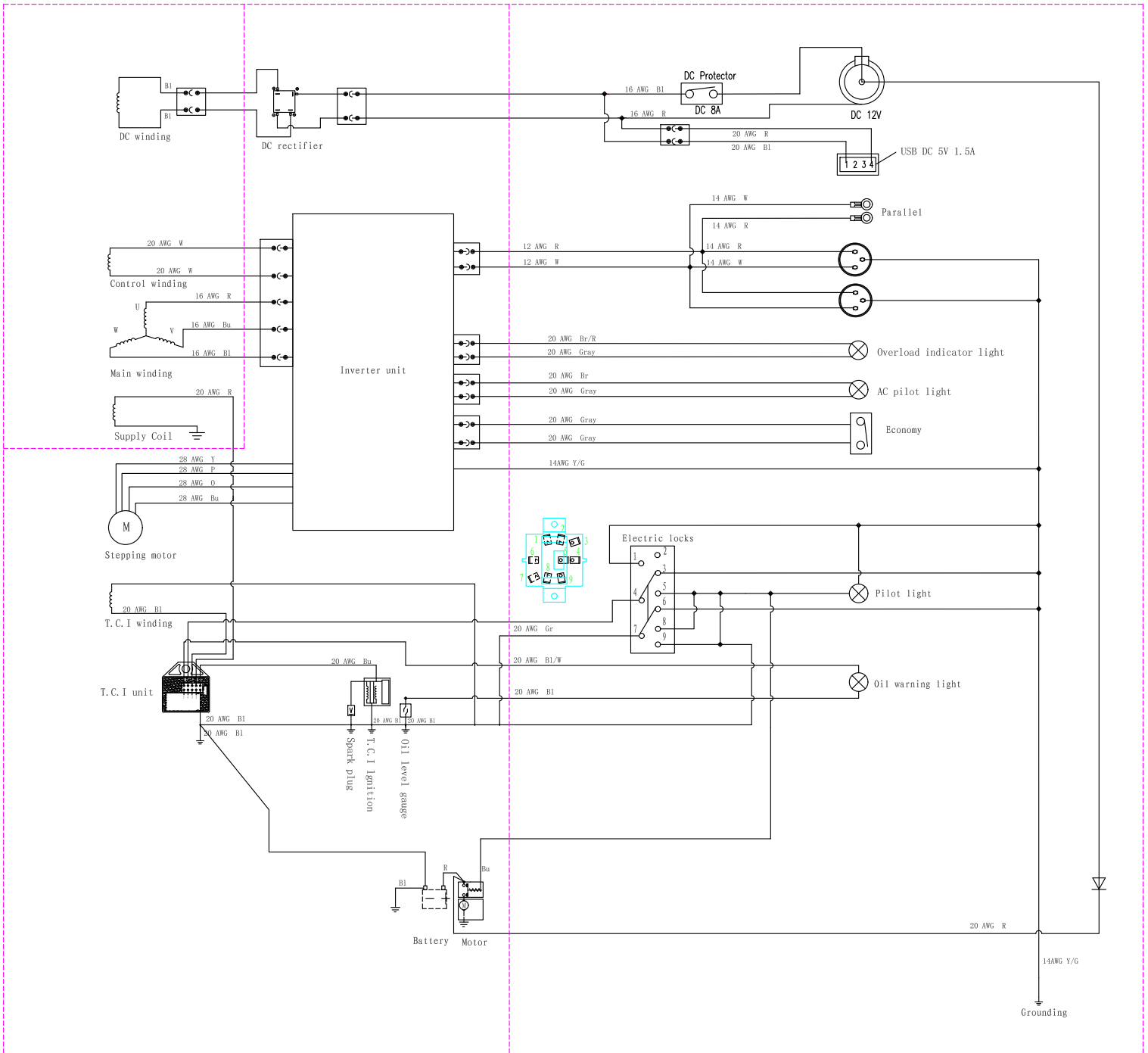

Bl	Black	Br	Brown	Y/G	Yellow green
R	Red	Br/R	Brown/red	Bl/W	???
Bu	Blue	Gr	Gray	Y	Yellow
W	White	P	Pink	0	Orange
Y	Yellow	Bl/W	Black/white	Zr	紫色